



A distributed automation system does not contain any central automated control cabinets. Controls, sensors and actuators are designed for a high degree of protection (IP 65 / IP 67) and are installed directly in the field. In connection with these innovative installation concepts with distributed devices, users are demanding a standard connector family that is compatible with all interfaces. In response to these needs, the HARTING PushPull series has set the respective new appliance connection standard. PushPull technology is available for data, signal and power applications. Other interfaces accommodating USB or fiber optics (LC, SCRJ) supplement the universal range of the PushPull solutions. The integration of communication and power lines in a hybrid PushPull connector is a genuine trend-setting advance. In view of these strengths, the PushPull container has become the standard for current and future appliance interfaces. The German automotive industry, for example, has opted for the implementation of the PushPull connector family.

*Application profile:*

| CONNECTION TYPE        |                     | ENVIRONMENT        |                 | APPLICATION |            |                         |                    |                           |                                     |                          |  |  |
|------------------------|---------------------|--------------------|-----------------|-------------|------------|-------------------------|--------------------|---------------------------|-------------------------------------|--------------------------|--|--|
| Board to Board         | Cable/Wire to Board | IP 20              | IP 65 / IP 67   | Data        | Signal     | Power                   | high performance   |                           |                                     |                          |  |  |
|                        |                     |                    |                 |             |            |                         | Data transfer rate | Shielding                 | Number of contacts, contact density | Voltage, working current |  |  |
|                        |                     |                    |                 |             |            |                         |                    |                           |                                     |                          |  |  |
| Cable termination      |                     |                    | PCB termination |             |            | Application standard    |                    |                           |                                     |                          |  |  |
| <i>Han-Quick Lock®</i> | <i>IDC HARAX®</i>   | <i>Crimp</i>       | <i>THT</i>      | <i>SMC</i>  | <i>SMT</i> |                         |                    |                           |                                     |                          |  |  |
|                        |                     |                    |                 |             |            |                         |                    |                           |                                     |                          |  |  |
| <i>Screw</i>           | <i>Cage clamp</i>   | <i>Axial screw</i> | <i>Press-in</i> |             |            |                         |                    |                           |                                     |                          |  |  |
|                        |                     |                    |                 |             |            |                         |                    |                           |                                     |                          |  |  |
|                        |                     |                    |                 |             |            | Housing integration     |                    |                           |                                     |                          |  |  |
|                        |                     |                    |                 |             |            | <i>Separate housing</i> |                    | <i>Integrated housing</i> |                                     |                          |  |  |
|                        |                     |                    |                 |             |            |                         |                    |                           |                                     |                          |  |  |

<sup>1)</sup> Piercing contacts

| CONTENTS  | PAGE  |
|---|-------|
| Introduction PushPull termination technology                        | 02.02 |
| HARTING PushPull type acc. to IEC 61 076-3-106 variant 4            |       |
| HARTING PushPull – housing bulkhead mounting for device integration | 02.04 |
| HARTING PushPull RJ45   | 02.05 |
| HARTING PushPull LC duplex  | 02.08 |
| HARTING PushPull Hybride – Introduction                             | 02.10 |
| HARTING PushPull Hybride  | 02.11 |
| HARTING PushPull Power – Introduction                               | 02.14 |
| HARTING PushPull Power, 4-poles, 48 V (12 A)                        | 02.15 |
| HARTING PushPull Power, 3-poles, 250 V (16 A)                       | 02.17 |
| HARTING PushPull Power – Tooling                                    | 02.18 |
| Han® PushPull type acc. to IEC/PAS 61 076-3-117 variant 14          |       |
| Han® PushPull RJ45  | 02.19 |
| Han® PushPull SCRJ  | 02.28 |
| Han® PushPull Power 4/0, 5-poles, 230/400 V (16 A)                  | 02.34 |
| Han® PushPull Power 4/0 – Contacts and toolings                     | 02.40 |
| Han® PushPull Power L 4/0, 5-poles, 24 V (16 A)                     | 02.41 |

The PushPull connector housing is a function container with degree of protection IP 65 / IP 67 and is available in two standardized housing sizes. These containers are equipped with standard RJ45, FOC or power contacts for operation at 5 x 16 A, depending on application requirements. The PushPull connector can be delivered either as plastic, or as metal variant, depending on the installation environment.

### THE PushPull PRINCIPLE

PushPull connector applications combine two basic advantages:

1. Simple operation
2. Safe and vibration resistant sealed IP 65 / IP 67 connection.

The innovative PushPull lock mechanism dispenses with the need for a latching bracket. The connector can be inserted with one hand, minimum force and an audible click for safe operation. The connection can be removed again just as easily for service work.

### COPPER, FOC AND POWER – IN THE SAME DESIGN

HARTING offers two series of the PushPull connector system, which differ in terms of their outer dimensions and module inserts.

#### Han® PushPull (IEC/PAS 61 076-3-117 VARIANT 14)

This series represents the standard PROFINET device interface for the IP 67 environment of the German automobile manufacturing industry.

The connector is available as metal and as plastic version. The RJ45 module for copper conductors and the SCRJ module for FOCs are available as data connectors. The RJ45 variant is realized by means of the RJ Industrial module equipped with HARAX® quick connection technology. The power module which is installed in the same container can be assembled on-site, either with crimp contacts or with innovative Quick Lock® technology in order to wire the distributed field devices to 230/400 V (16 A) power. This 5-pole connector enables the transfer of two



independent 24 V control circuits with functional ground, or the transfer of a three-phase voltage of 400 V (16A).

#### HARTING PushPull (IEC 61 076-3-106 VARIANT 4)

This extremely compact and space-saving series provides an Ethernet appliance connection with degree of protection IP 65 / IP 67 that requires no more installation space than a M12 connector. The RJ45 variant for copper conductors and the LC variant for FOCs are available as modules for data connectors. The RJ45 variant is realized by means of HARAX® quick connection technology as used with HARTING RJ Industrial®. The 4-pole module for 48 V (12 A) or the 3-pole module for 250 V (16 A) can be used to supply power to the distributed field devices.

#### HARTING PushPull HYBRID

The migration from Fieldbus to Ethernet within communication technology has simplified machine installation options. This

simplification is attained by combining the data and the 24 V power lines in a single hybrid cable with hybrid connector, in connection with the spatial requirements of an M12 connector. The HARTING PushPull Hybrid offers trend-setting connection technology for this new method of machine installation.

The PushPull Hybrid reduces everything by half: the number of connection points and cables, and spatial requirements for the connection technology.

The PushPull Hybrid makes everything easier: machine installation, the wiring of connectors and safe insertion.

#### APPLIANCE INTEGRATION:

In order to support the implementation of appliances with degree of protection IP 65 / IP 67, HARTING offers panel feed-through devices with integrated couplings and female contact modules for direct mounting on PCBs.

#### HARTING PushPull

##### ONE CONCEPT FOR DATA, SIGNAL AND POWER

The internationally standardized PushPull connector represents the latest generation of appliance connection technology with high degree of protection IP 65 / IP 67, easy insertion and snap-action engagement with audible click.

The PushPull housing family is designed for the integration of a wide range of contact inserts for data, signal and power lines.

#### INSTALLATION IN PLANTS

##### WITH Han® PushPull CONNECTORS:

- The standard for PROFINET communication
- One housing for the electrical and optical data transfer and for power supply
- Plastic or metal housing variants

#### INSTALLATION IN MACHINES

##### WITH HARTING PushPull HYBRID CONNECTORS:

- Combined data lines and appliance power supply up to 5 A in the same connector
- Compact size (comparable with M12)
- Straight and angled connector design, suitable for on-site assembly and overmolded

#### POWER SUPPLY TO DISTRIBUTED DEVICES

##### USING PushPull CONNECTORS:

- Variant 4: 48 V (12 A), 4-pole or 250 V (16 A), 3-pole
- Variant 14: 400 V (12 A) 5-pole, or 24 V (16 A) 5-pole
- Latest connection technology QuickLock® for on-site assembly without special auxiliary tools





HARTING PushPull Technology acc. to IEC 61076-3-106 variant 4 housing bulkhead mounting for device integration of RJ45- and Power-jacks

PushPull

## Advantages

- PushPull housing bulkhead mounting with HARTING PushPull technology
  - Compact, space-saving design for device integration of RJ45- or Power-pcb female
- Housing bulkhead mounting EasyInstall
- for simple device integration round panel cut out
- Housing bulkhead mounting Compact
- high packing density (spacing 27 x 21 mm)

## Technical characteristics

|                            |  |
|----------------------------|--|
| Locking                    | PushPull Technology acc. to IEC 61 076-3-106 variant 4 |
| Transmission rate          | 10/100/1000 Mbit/s                                     |
| Shielding                  | fully shielded, 360° shielding contact                 |
| Mating cycles              | min. 750   |
| Degree of protection       | IP 65 / IP 67  |
| Temperature range          | - 40 °C up to + 70 °C                                  |
| Housing material           | Plastic, black   |
| Flammability acc. to UL 94 | V 0  |
|                            | UL approval (E102079)                                  |

| Identification | Part No. | Drawing | Dimensions in mm |
|----------------|----------|---------|------------------|
|----------------|----------|---------|------------------|

### Components device side

Housing bulkhead mounting – EasyInstall with integrated seal board drillings for M3

without fixing clip

09 45 545 0030

with fixing clip

09 45 545 0031

Housing bulkhead mounting – Compact incl. flat seal board drillings for M2.5

without fixing clip

09 45 545 0023

with fixing clip

09 45 545 0021

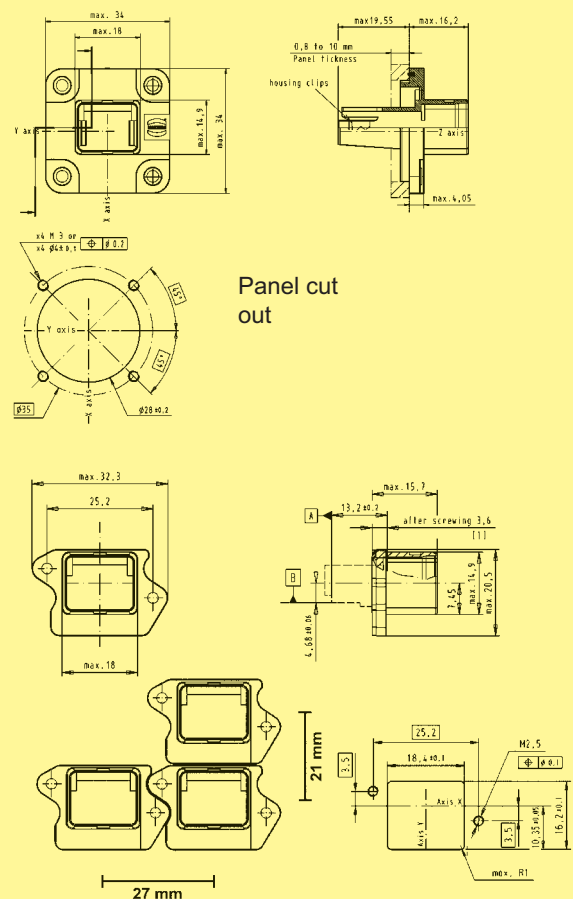







HARTING PushPull Technology acc. to IEC 61 076-3-106 variant 4  
RJ45-connector

## Advantages

- Ethernet connector based on RJ45
- Fully shielded, 360° shielding contact
- Field-assembly connector with IDC contacts (Cat. 5 versions) or piercing contacts (Cat.6 versions)

## Technical characteristics

|   |   |
|---|---|
| Locking   | PushPull Technology acc. to IEC 61 076-3-106 variant 4            |
| Degree of protection  | IP 65 / IP 67   |
| Mating face   | RJ45 acc. to IEC 60 603-7   |
| Cable diameter  | 5.8 ... 7.2 mm  |
| Termination cross section   |   |
| Cat. 5  | AWG 24/7 ... AWG 22/7 (stranded)<br>AWG 23/1 ... AWG 22/1 (solid) |
| Cat. 6  | AWG 24/7 ... AWG 27/7 (stranded)                                  |
| Mating cycles   | min. 750  |
| Temperature range   | -40 °C up to +70 °C   |
| Housing material  | Plastic, black  |
| Flammability acc. to UL 94  | V 0   |
|  | UL approval (E102079)   |

PushPull

| Identification | Part No. | Drawing | Dimensions in mm |
|----------------|----------|---------|------------------|
|----------------|----------|---------|------------------|

Connector, 4-poles  
Cat. 5  
incl. housing with RJ45 connector, shielding and cable gland

09 45 145 1100

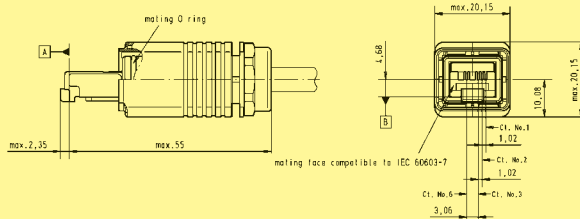

Connector, 8-poles  
Cat. 6  
incl. housing with RJ45 connector, shielding and cable gland

Wire manager white

09 45 145 1500

Wire manager blue

09 45 145 1510

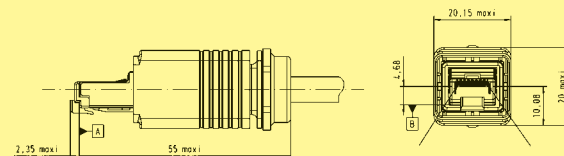

Reference note:  
For cat. 6 patch cords it is recommended to use 1 connector with a white wire manager and one with an blue cable manager, in order to optimise the crosstalk between different signal pairs.

Tools

see page 01.08

System cables in different versions

see catalogue " Ethernet Network Solutions for Industry"





HARTING PushPull type acc. to IEC 61 076-3-106 variant 4  
LC duplex panel feed-through and connector

PushPull

## Advantages

- Optical PushPull connector based on LC with small form factor (requires 50 % compared to SC and ST)
- EasyInstall panel feed-through for simple device integration
- Optical module with inserts acc. to IEC 61 754-20
- One-piece LC body assures high mechanical stability
- A & B parts identification for Duplex according TIA 568 standard

## Technical characteristics

|                            |  |
|----------------------------|--|
| Locking                    | PushPull Technology acc. to IEC 61 076-3-106 variant 4 |
| Degree of protection       | IP 65 / IP 67  |
| Mating face                | LC acc. to IEC 61 754-20                               |
| Cable diameter             | 5.8 ... 7.2 mm   |
| Mating cycles              | min. 200   |
| Temperature range          | -40 °C up to +70 °C                                    |
| Housing material           | Plastic, black   |
| Flammability acc. to UL 94 | V 0  |

| Identification | Part No. | Drawing | Dimensions in mm |
|----------------|----------|---------|------------------|
|----------------|----------|---------|------------------|

### HARTING PushPull LC duplex

#### Cable side

Multimode GOF  
Singlemode GOF

09 57 402 0500 000  
09 57 402 0501 000

#### Device side EasyInstall

Multimode GOF  
Singlemode GOF

09 57 441 0500 000  
09 57 441 0501 000

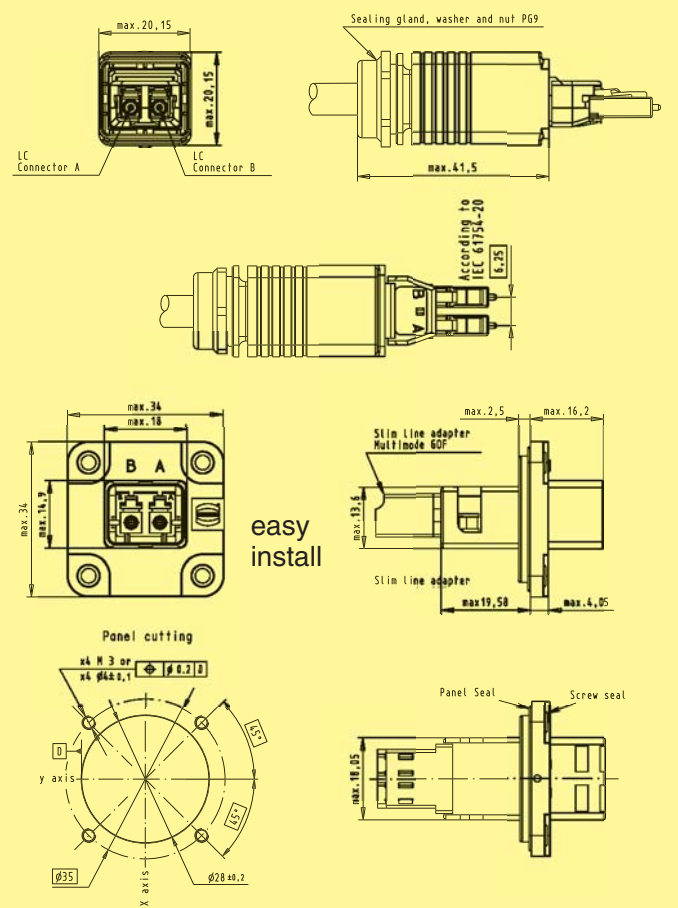



LC duplex IP 20 adapter for device integration

## Advantages

- Small form factor requires 50 % (compared to SC and ST)
- Compact, space-saving design
- High packing density
- A & B parts identification according TIA 568 standard
- Complement adapter for IP 67 connector on device side

## Technical characteristics

|                      |                           |
|----------------------|---------------------------|
| Degree of protection | IP 20                     |
| Mating interface     | LC duplex with two fibres |
| Temperature range    | -40 °C up to +70 °C       |

PushPull

| Identification | Part No. | Drawing | Dimensions in mm |
|----------------|----------|---------|------------------|
|----------------|----------|---------|------------------|

Device side

Adapter

- Multimode GOF
- Singlemode GOF

09 57 400 0003 000  
09 57 400 0004 000

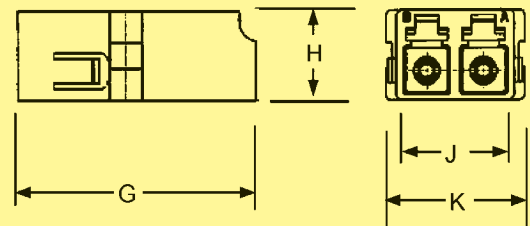

|   | min.  | max.  |
|---|-------|-------|
| G | 26.60 | 26.80 |
| H | 9.35  | 9.45  |
| J | 12.80 | 12.90 |
| K | 15.24 | 15.34 |

Connector  
LC duplex

- Multimode GOF
- Singlemode GOF

09 57 400 0001 000  
09 57 400 0002 000

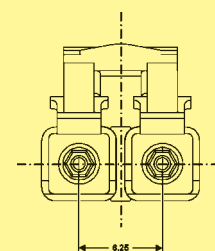
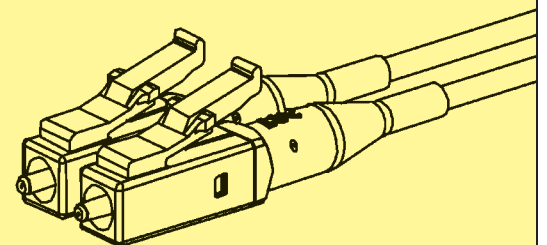



HARTING PushPull Hybrid  
type acc. to IEC 61 076-3-106 variant 4

## Advantages

HARTING PushPull Hybrid

In the future all new machine generations will be equipped with Fast Ethernet, no matter if PROFINET, Ethernet/IP, Powerlink, Ethercat, Varan or other Ethernet profiles.

With the change of the communication technology also the possibility is offered of simplifying the machine installation and of introducing an innovative Hybrid installation concept. This simplification will unite by data and 24V (5A)-supply in a Hybrid cable, at least with the space requirement of a M12-connector.

For this new installation solution HARTING with the HARTING PushPull Hybrid offers the trend-setting installation technology.

Everything is halved: the number of pluggings, the number of cables and the space requirement for the connection technology. Everything becomes simpler: the installation, attaching and safe plugging.

The Hybrid connectors were developed particular under the criteria of simple attaching in the field and the particular safe data communication with the patented omega screen concept. As contacts D-Sub and HDD Sub contacts worked world-wide are used. This socket pin contact system ensures highest reliability and optimal shock and vibration stability.

With the optional available coding pins 6 different codings can be realized.

This connector is available in the variants straight or angled as well as for field assembling or overmolded.

## Technical characteristics

### Advantages

- Compact, space-saving design
- Very compact housing with high degree of protection
- Polarisation with nose
- Sixfold codable

### Typical application areas

- Factory and building automation
- Industrial electronics
- Telecommunication and wireless networks
- Transportation
- Industrial monitoring and camera systems
- Lighting and display technology
- Access control systems

### Recommended pin assignment

- Power contacts

| Contact | Function       | Conductor colour |
|---------|----------------|------------------|
| 1       | V +            | Red              |
| 2       | Ground         | Brown            |
| 3       | V + (switched) | Yellow           |

- Data contacts

| Contact | Signal | Function            | Conductor colour |
|---------|--------|---------------------|------------------|
| 4       | RD -   | Receiver Data -     | Blue             |
| 5       | RD +   | Receiver Data +     | White            |
| 6       | TD -   | Transmission Data - | Orange           |
| 7       | TD +   | Transmission Data + | Yellow           |



Structure Hybrid cable  
Data: 4x AWG26/7  
Power: 3x AWG20/7



HARTING PushPull Hybrid, type acc. to IEC 61 076-3-106 variant 4 device side

## Advantages

- Combined data- and power-supply up to 5A/32V included to one connector
- HARTING PushPull technology
- Compact design
- High packing density
- Sixfold codable
- Suitable for all Fast-Ethernet variants

## Technical characteristics

|                            |   |
|----------------------------|---|
| Locking                    | PushPull Technology acc. to IEC 61 076-3-106 variant 4                          |
| Degree of protection       | IP 65 / IP 67   |
| Termination                | Solder pins   |
| Transmission performance   | Category 5 / Class D up to 100 MHz acc. to ISO/IEC 11 801:2002, EN ISO 50 173-1 |
| Transmission rate          | 10 / 100 Mbit/s   |
| Number of contacts         | Data: 4, shielded (Ethernet)<br>Power: 3, (5A / 32V)                            |
| Housing material           | Plastic, black  |
| Flammability acc. to UL 94 | V 0   |

| Identification | Part No. | Drawing | Dimensions in mm |
|----------------|----------|---------|------------------|
|----------------|----------|---------|------------------|

### Components device side

#### Set straight

HARTING PushPull Hybrid housing bulkhead mounting and pcs female shielded, IP 65 / IP 67, black, 180° straight

09 45 245 1300

#### Set angled

HARTING PushPull Hybrid housing bulkhead mounting and pcs female shielded, IP 65 / IP 67, black, 90° angled

09 45 245 1310  
(in preparation)

#### Female insert

PCB jack shielded 180° straight

09 45 545 1300

PCB jack shielded 90° angled

09 45 545 1305  
(in preparation)

#### Housing bulkhead mounting

for female insert straight  
for female insert angled

09 45 545 1320

09 45 545 1325  
(in preparation)

#### Panel feed-through

1 x Hybrid female IP 65 / IP 67 on  
1 x RJ45 female and 3 pcb clamps,  
board drillings for M2.5

09 45 245 1320

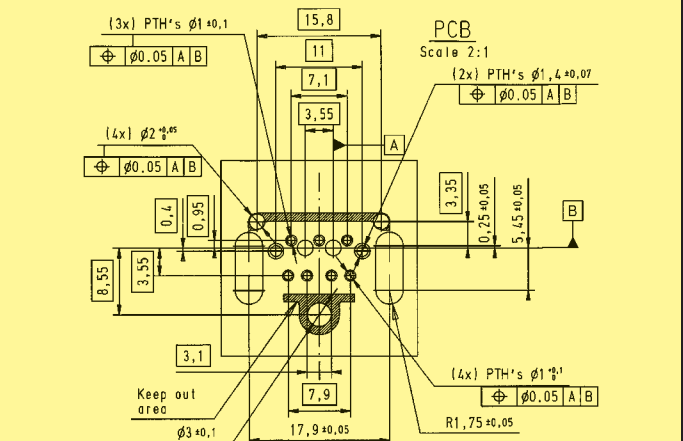
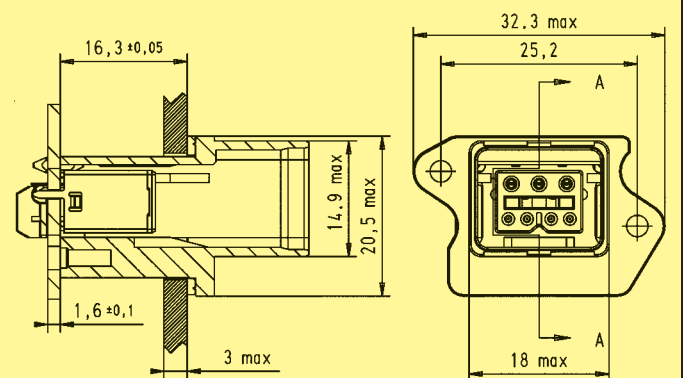

## HARTING PushPull Hybrid



HARTING PushPull Hybrid, type acc. to IEC 61 076-3-106 variant 4  
Hybrid connector

PushPull

### Advantages

- Combined data- and power-supply up to 5A / 32V included to one connector
- HARTING PushPull technology
- Compact design
- High packing density
- Sixfold condable
- Suitable for all Fast-Ethernet variants

### Technical characteristics

|                            |   |
|----------------------------|---|
| Locking                    | PushPull Technology acc. to IEC 61 076-3-106 variant 4                                |
| Degree of protection       | IP 65 / IP 67   |
| Termination                | Crimp   |
| Cable diameter             | AWG 26 for Ethernet<br>AWG 20 for Power   |
| Transmission performance   | Category 5 / Class D<br>up to 100 MHz acc. to ISO/IEC 11 801:2002,<br>EN ISO 50 173-1 |
| Number of contacts         | Data: 4, shielded (Ethernet)<br>Power: 3, (5A / 32V)                                  |
| Housing material           | Plastic, black  |
| Flammability acc. to UL 94 | V 0   |

| Identification | Part No. | Drawing | Dimensions in mm |
|----------------|----------|---------|------------------|
|----------------|----------|---------|------------------|

#### Connector

HARTING PushPull Hybrid connector, IP 65/ 67, black, with cable gland and crimp contacts

straight

09 45 145 1300

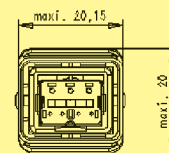
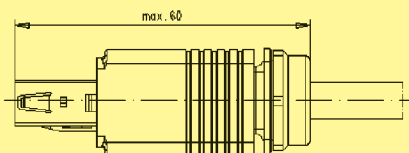

#### Accessories – Coding pin set

to avoid accidental incorrect mating a coding system is required. This coding pins are inserted without loss of contact.

09 45 845 1300

#### Tools

Crimping tool for data contacts

09 99 000 0596

Crimping tool for power contacts

09 99 000 0175



#### Insertion and removal tool for data contacts

09 99 000 0513



#### Insertion and removal tool for power contacts

09 99 000 0171





HARTING PushPull Hybrid, type acc. to IEC 61 076-3-106 variant 4 overmoulded Hybrid system cables

## Advantages

- Combined data- and power-supply up to 5A / 32V included to one connector
- HARTING PushPull technology
- Robust design, suitable for industrial applications
- High packing density
- Sixfold codable
- Suitable for all Fast-Ethernet variants

## Technical characteristics

|                          |   |
|--------------------------|---|
| Cable construction:      | Twisted Pair shielded + 3 Power cables  |
| Core structure           | Data: 4x AWG 26/7<br>Power: 3x AWG 20/7   |
| Transmission performance | Category 5 / Class D up to 100 MHz acc. to ISO/IEC 11 801:2002, EN ISO 50 173-1 |
| Sheath material          | FRNC  |
| Cable-outer diameter     | ∅ (7.0 ±0.4) mm   |
| Shielding                | Shielding foil and shielding braid  |
| Temperature range        | - 40 up to + 80 °C  |
| Colour                   | black   |

PushPull

|                |          |         |                  |
|----------------|----------|---------|------------------|
| Identification | Part No. | Drawing | Dimensions in mm |
|----------------|----------|---------|------------------|

### System cables 2x HARTING PushPull Hybrid

|        |       |                |
|--------|-------|----------------|
| Length | 0,5 m | 09 47 616 1005 |
|        | 1 m   | 09 47 616 1010 |
|        | 2 m   | 09 47 616 1020 |
|        | 3 m   | 09 47 616 1030 |
|        | 5 m   | 09 47 616 1050 |
|        | 10 m  | 09 47 616 1100 |
|        | 20 m  | 09 47 616 1200 |

### System cables 1x HARTING PushPull Hybrid, second side open

|        |       |                |
|--------|-------|----------------|
| Length | 0,5 m | 09 47 610 0005 |
|        | 1 m   | 09 47 610 0010 |
|        | 2 m   | 09 47 610 0020 |
|        | 3 m   | 09 47 610 0030 |
|        | 5 m   | 09 47 610 0050 |
|        | 10 m  | 09 47 610 0100 |
|        | 20 m  | 09 47 610 0200 |

### Hybrid cable

|         |       |                |
|---------|-------|----------------|
| Ring    | 20 m  | 09 45 600 0331 |
| Ring    | 50 m  | 09 45 600 0341 |
| Ring    | 100 m | 09 45 600 0301 |
| Trommel | 500 m | 09 45 600 0321 |



Structure Hybrid cable

HARTING offers with the Han® PushPull S Power connector an universal solution for the power supply in compact and robust applications. It is in its element wherever small dimensions are combined with a high protection class.

The connector is available in a 4-pole 48 V and a 2-pole 250 V version. The power contacts can carry up to 12 resp. 16 A each (see deratings). In spite of this high current carrying capacity the connector gets by with minimal dimensions and fulfils the industrial requirements for clearances and creepage distances at the same time (pollution degree 3 and overvoltage category III).

Additionally the Han® PushPull S Power connector offers the protection class of IP 67 and 65. Beside numerous industrial use cases it is thereby suited for diverse applications in the fields of transportation and telecommunication.

The cable side of the Han® PushPull S Power is terminated with crimping technology. For the receptacle several solutions with different termination technologies are offered.

- Regulations**
- VDE 0110
  - DIN EN 61984

**Advantages**

- Minimum space requirements in spite of high current carrying capacity
- Very compact housing in a high protection class
- Protection against contact on plug AND receptacle side enables an easy and safe installation
- For low voltage (48 V) and for power supply (250 V) available
- Codeable without losing contacts
- Different termination technologies for individual device integration

**Typical application areas**

- Factory and building automation
- Industrial electronics
- Telecommunication and wireless networks
- Transportation
- Industrial monitoring and camera systems
- Lighting and display technology
- Access control systems

**Current carrying capacity**

The current carrying capacity is determined in tests which are conducted on the basis of the DIN IEC 60512-5-2. The current carrying capacity is limited by the thermal properties of materials which are used for inserts as well as by the insulating materials. These components have a limiting temperature which should not be exceeded.

**Example of a current capacity curve**

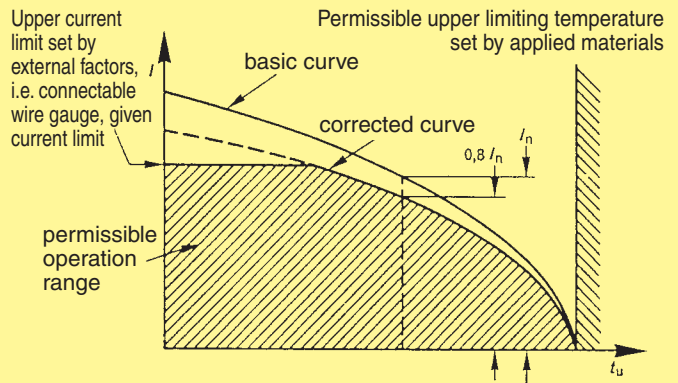

Derating-Diagramm for low voltage, 48V; 4x 12A

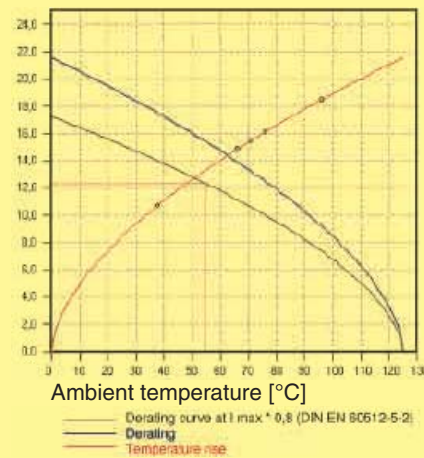

Derating-Diagramm for power supply, 250 V; 2x 16A

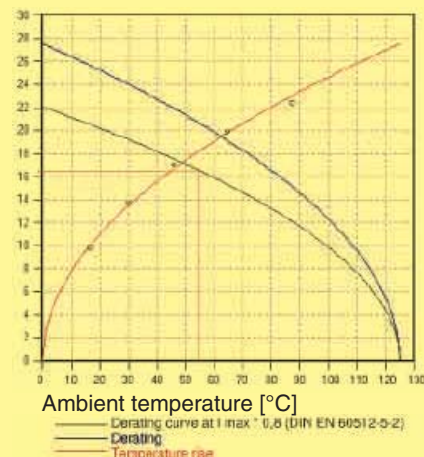



HARTING PushPull Power 4/0, type acc. to IEC 61 076-3-106 variant 4  
panel feed-throughs 4-poles 48V / 12A

## Advantages

- Power connectors for devices
- EasyInstall and Compact panel feed-through and females for simple device integration
- Compact, space-saving design
- Touch-proof according to IEC DIN EN 60 529
- Polarisation with nose
- Device side: female with cable cage, crimp or solder termination
- 4 different coding variants without loss of contact

## Technical characteristics

|                                   |  |
|-----------------------------------|--|
| Locking                           | PushPull Technology acc. to IEC 61 076-3-106 variant 4 |
| Degree of protection              | IP 65 / IP 67  |
| Number of contacts                | 4  |
| Electrical data acc. to EN 61 984 | 12 A 48 V 1.5 kV 3                                     |
| Termination                       | Crimp  |
| Termination cross section         | 0.75 - 2.5 mm <sup>2</sup> (AWG 20 - 12) stranded      |
| Termination                       | Solder pins  |
| Termination diameter              | 1.6 mm   |
| Termination                       | Cable cage   |
| Termination cross section         | 0.75 - 2.5 mm <sup>2</sup> (AWG 20 - 12) stranded      |
| Mating cycles                     | min. 750   |
| Temperature range                 | -40 °C up to +70 °C                                    |
| Housing material                  | Plastic, black   |
| Flammability acc. to UL 94        | V 0  |

| Identification  | Part No.   | Drawing | Dimensions in mm |
|---|--|---------|------------------|
| <b>Panel feed-through set</b><br><br><b>Housing bulkhead mounting EasyInstall</b><br>with 4 turned female contacts and insulation<br><br>with crimp termination for 1.5 mm <sup>2</sup><br>with solder termination, 90° angled<br>with cage clamp terminal on pcb | 09 46 245 4430<br>09 46 245 4030<br>09 46 245 4031 |         |                  |
| <b>Housing bulkhead mounting Compact</b><br>with 4 turned female contacts and insulation<br><br>with crimp termination for 1.5 mm <sup>2</sup><br>with solder termination, 90° angled<br>with cage clamp terminal on pcb  | 09 46 245 4400<br>09 46 245 4000<br>09 46 245 4001 |         |                  |
| <b>Power-female with solder termination</b><br>4-poles, 48V/12A, 90° angled   | 09 46 500 4400                                     |         |                  |
| <b>Accessories – crimp contacts female</b><br>0.75 mm <sup>2</sup> (AWG 20 - 18)<br>1.5 mm <sup>2</sup> (AWG 16 - 14)<br>2.5 mm <sup>2</sup> (AWG 12)   | 09 46 500 0404<br>09 46 500 0402<br>09 46 500 0406 |         |                  |

PushPull





HARTING PushPull Power 4/0, type acc. to IEC 61076-3-106 variant 4  
connector 4-poles 48V / 12A

PushPull

## Advantages

- Power connectors for devices
- EasyInstall panel feed-through for simple device integration
- Compact, space-saving design
- Touch-proof according to IEC DIN EN 60 529
- Polarisation with nose
- Cable side: Male with crimp termination
- 4 different coding variants without loss of contact

## Technical characteristics

|                                   |  |
|-----------------------------------|--|
| Locking                           | PushPull Technology acc. to IEC 61 076-3-106 variant 4 |
| Degree of protection              | IP 65 / IP 67  |
| Number of contacts                | 4  |
| Electrical data acc. to EN 61 984 | 12 A 48 V 1.5 kV 3                                     |
| Cable diameter                    | 5.8 ... 7.2 mm   |
| Termination                       | Crimp  |
| Termination cross section         | 0.75 - 2.5 mm <sup>2</sup> (AWG 20 - 12) stranded      |
| Mating cycles                     | min. 750   |
| Temperature range                 | -40 °C up to +70 °C                                    |
| Housing material                  | Plastic, black   |
| Flammability acc. to UL 94        | V 0  |

| Identification  | Part No.   | Drawing | Dimensions in mm |
|---|--|---------|------------------|
| <b>Connector set</b><br>incl. 4 turned crimp contacts (male), insulation, housing, cable gland  | 09 46 145 4400                                     |         |                  |
| <b>Accessories – crimp contacts male</b><br>0.75 mm <sup>2</sup> (AWG 20 - 18)<br>1.5 mm <sup>2</sup> (AWG 16 - 14)<br>2.5 mm <sup>2</sup> (AWG 12)             | 09 46 500 0403<br>09 46 500 0401<br>09 46 500 0405 |         |                  |
| <b>Accessories – Coding pin set</b><br>to avoid accidental incorrect mating a coding system is required. This coding pins are inserted without loss of contact. | 09 46 840 0000                                     |         |                  |
| <b>Accessories – protection cover IP 65 / IP 67</b><br>for connector with cord<br><br>for device side with cord   | 09 45 845 0001<br><br>09 45 845 0009               |         |                  |
| <b>Accessories – transport protection IP40</b><br>for housing bulkhead mounting, rubber   | 09 45 845 0003                                     |         |                  |

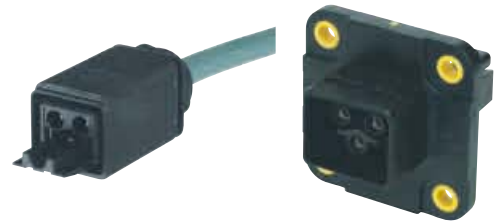

HARTING PushPull Power 2/0, type acc. to IEC 61 076-3-106 variant 4 panel feed-through and connector, 3-poles, 250 V / 16 A

### Advantages

- Power connectors for devices
- EasyInstall panel feed-through for simple device integration
- Compact, space-saving design
- Touch-proof according to IEC DIN EN 60 529
- Polarisation with nose
- Cable side: Male with crimp termination
- Device side: female with crimp termination
- 4 different coding variants without loss of contact

### Technical characteristics

|                                   |  |
|-----------------------------------|--|
| Locking                           | PushPull Technology acc. to IEC 61 076-3-106 variant 4 |
| Degree of protection              | IP 65 / IP 67  |
| Number of contacts                | 2 + PE   |
| Electrical data acc. to EN 61 984 | 16 A 250 V 4 kV 3                                      |
| Cable diameter                    | 5.8 ... 7.2 mm   |
| Termination                       | Crimp  |
| Termination cross section         | 0.75 - 2.5 mm <sup>2</sup> (AWG 20 - 12) stranded      |
| Mating cycles                     | min. 750   |
| Temperature range                 | -40 °C up to +70 °C                                    |
| Housing material                  | Plastic, black   |
| Flammability acc. to UL 94        | V 0  |

PushPull

| Identification | Part No. | Drawing | Dimensions in mm |
|----------------|----------|---------|------------------|
|----------------|----------|---------|------------------|

#### HARTING PushPull Power 2/0

##### Panel feed-through set

incl. 3 turned crimp contacts (female), insulation (black), housing bulkhead mounting EasyInstall

09 46 245 3430

##### Panel feed-through set

incl. 3 turned female contacts, insulation (black), housing bulkhead mounting, with crimp termination

09 46 245 3410

##### Connector set

incl. 3 turned crimp contacts (male), insulation (black), housing, cable gland

09 46 145 3410

##### Coding pin set

to avoid accidental incorrect mating a coding system is required. This coding pins are inserted without loss of contact.

09 46 840 0000

##### Protection cover IP 65 / 67

with cord

09 45 845 0001

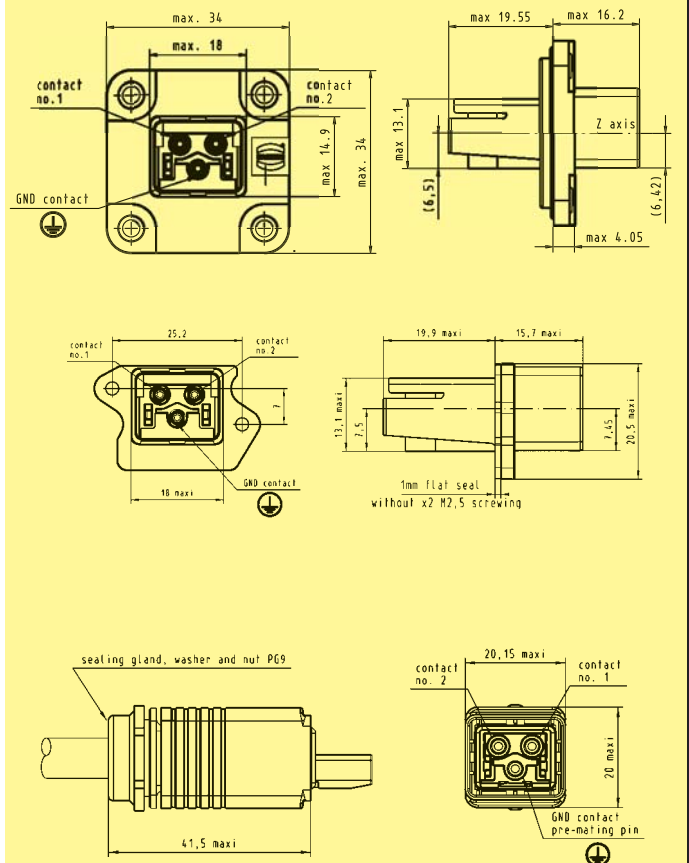

PushPull

| Identification  | Part No.       |
|---|----------------|
| Han® PushPull Power 8-indent crimping tool                | 09 46 800 0000 |
| Locator HARTING PushPull Power contacts for crimping tool | 09 46 800 0010 |
| Crimping tool depth adjustment gauge                      |                |
| Ø 1.02 mm   | 09 46 800 0002 |
| Ø 1.15 mm   | 09 46 800 0003 |
| Insertion tool  | 09 46 800 0099 |
| Extraction tool   | 09 46 800 0098 |



For wire gauges 0.08 ... 4.0 mm<sup>2</sup> (AWG 28 ... 12).

For the fine adjustment of the crimping depth of the Han® PushPull Power 8-indent crimping tool.

| Wire  | Gauge     |
|---|-----------|
| 0.25 mm <sup>2</sup> ... 1.50 mm <sup>2</sup> | Ø 1.02 mm |
| 1.50 mm <sup>2</sup> ... 2.50 mm <sup>2</sup> | Ø 1.15 mm |



For an easy insertion and extraction of the male and female crimp contacts into / out of the insulator body.

### Crimp connection

A perfect crimp connection is gastight, therefore corrosion free and amounts to a cold weld of the parts being connected. For this reason, major features in achieving high quality crimp connections are the design of the contact crimping parts and of course the crimping tool itself. Wires to be connected must be carefully matched with the correct size of crimp contacts. If these basic requirements are met, users will be assured of highly reliable connections with low contact resistance and high resistance to corrosive attack.

The economic and technical advantages are:

- Constant contact resistance as a result of precisely repeated crimp connection quality
- Corrosion free connections as a result of cold weld action
- Pre-preparation of cable forms with crimp contacts fitted
- Optimum cost cable connection

Requirements for crimp connectors are laid down in DIN IEC 60352-2, Amend. 2, as illustrated in the table.

#### Pull out force of stranded wire

The main criterion to judge the quality of a crimp connection is the retention force achieved by the wire conductor in the terminal section of the contact. DIN IEC 60352, part 2, defines the extraction force in relation to the cross-section of the conductor. When fitted using HARTING crimping tools and subject to their utilization in an approved manner, our crimp connectors comply with the required extraction forces.

### Crimping tools

Crimping tools (hand operated or automatic) are carefully designed to produce with high pressure forming parts a symmetrical connection of the crimping part of the contact and the wire being connected with the minimum increase in size at the connection point. The positioner automatically locates the crimp and wire at the correct point in the tool.

A ratchet in the tool performs 2 functions:

- ① It prevents insertion of the crimp into the tool for crimping before the jaws are fully open
- ② It prevents the tool being opened before the crimping action is completed

Identical, perfectly formed, connections can be produced using this crimping system.

### Tensile strength of crimped connections

| Conductor cross-section |     | Tensile strength |
|-------------------------|-----|------------------|
| mm <sup>2</sup>         | AWG | N                |
| 0.08                    | 28  | 11               |
| 0.12                    | 26  | 15               |
| 0.14                    |     | 18               |
| 0.22                    | 24  | 28               |
| 0.25                    |     | 32               |
| 0.32                    | 22  | 40               |
| 0.5                     | 20  | 60               |
| 0.75                    |     | 85               |
| 0.82                    | 18  | 90               |
| 1.0                     |     | 108              |
| 1.3                     | 16  | 135              |
| 1.5                     |     | 150              |
| 2.1                     | 14  | 200              |
| 2.5                     |     | 230              |
| 3.3                     | 12  | 275              |
| 4.0                     |     | 310              |

Extract from DIN IEC 60352-2, Amend. 2, Table IV

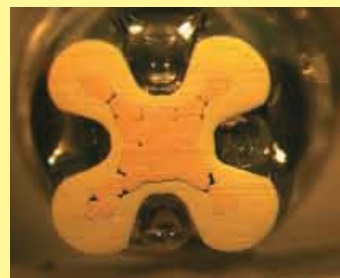

Crimp-cross section  
HARTING crimp profile





Han® PushPull, type acc. to IEC/PAS 61 076-3-117 variant 14  
RJ45 panel feed through

PushPull

**Features**

- HARTING PushPull technology
- Compact design
- High packing density
- Device integration via RJ45 PCB connectors

**Technical characteristics**

|                            |  |
|----------------------------|--|
| Locking                    | PushPull technology acc. to IEC/PAS 61 076-3-117 |
| Degree of protection       | IP 65 / IP 67                                    |
| Mating face                | RJ45 acc. to IEC 60 603-7                        |
| Termination type           | Female with solder termination                   |
| Mating cycles              | min. 750   |
| Temperature range          | -40 °C ... +70 °C                                |
| Housing material           | Plastic, black                                   |
| Flammability acc. to UL 94 | V 0  |

Identification      Part No.      Drawing      Dimensions in mm

**Han® PushPull RJ45**

Panel feed through including housing and printed board with 2 x RJ45 jack horizontally mounted

09 35 221 0331

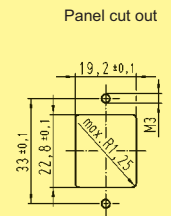
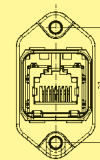
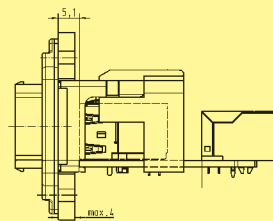

Panel feed through including housing and printed board with RJ45 jack and SEK board

09 35 222 0331

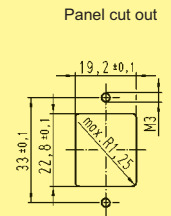
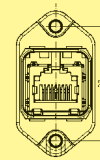
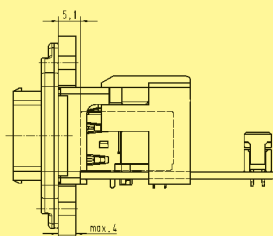

Panel feed through including housing and printed board with RJ45 jack and RJ45 jack vertically mounted in the IP20 range

09 35 223 0331

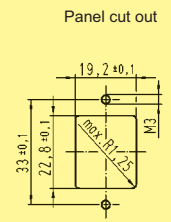
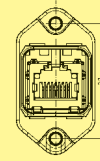
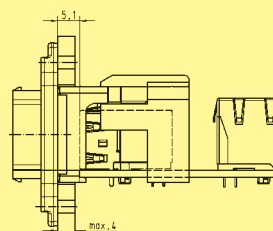

Identification

Part No.

Drawing

Dimensions in mm

Panel feed through including housing and printed board with RJ45 jack and 47° jack vertically mounted in the IP20 range

09 35 224 0331

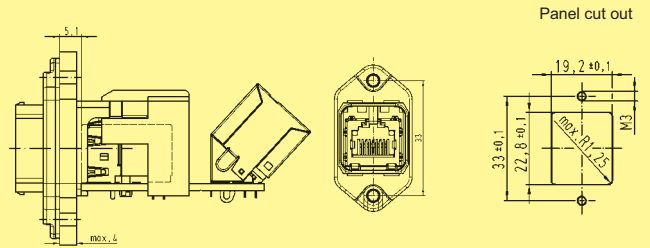

Panel feed through including housing and printed board with RJ45 jack and solder termination in the IP20 range

09 35 226 0331

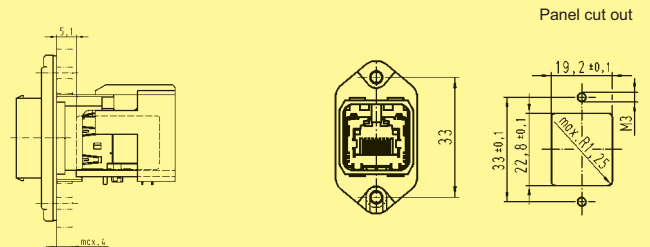

Recommendation for female insert and assembly manual on request.

PushPull



Han® PushPull, type acc. to IEC/PAS 61 076-3-117 variant 14 RJ45 connector

PushPull

## Features

- HARTING PushPull technology
- Compact design
- High packing density
- Field-assembly connector with IDC contacts (Cat. 5 versions) or piercing contacts (Cat. 6 versions)

## Technical characteristics

|                                      |   |
|--------------------------------------|---|
| Locking                              | PushPull technology acc. to IEC/PAS 61 076-3-117      |
| Degree of protection                 | IP 65 / IP 67   |
| Mating face                          | RJ45 acc. to IEC 60 603-7                             |
| Termination cross section for Cat. 5 | AWG 24/7 – 22/7 (stranded)<br>AWG 23/1 – 22/1 (solid) |
| for Cat. 6                           | AWG 24/7 – 27/7 (stranded)                            |
| Mating cycles                        | min. 750  |
| Temperature range                    | -40 °C ... +70 °C                                     |
| Housing material                     | Plastic, black  |
| Flammability acc. to UL 94           | V 0   |
| Cable diameter                       | 5 – 9.5 mm  |

### Identification

### Part No.

### Drawing

### Dimensions in mm

#### Connector set, plastic

incl. housing and male insert

Category 5, 4-poles  
HARTING RJ Industrial®

6.5 – 9.5 mm clamp range  
PROFINET-Identification:  
PROFINET O-Plug RJ45



5 – 8 mm clamp range



Category 6, 8-poles  
5 – 8 mm clamp range  
Wire manager, white

Wire manager, blue

09 35 221 0421

09 35 222 0421

09 35 223 0421

09 35 224 0421

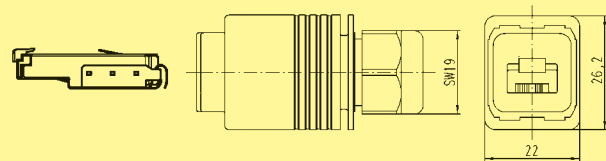

### Tools

see page 01.08

### Assembled system cables

see catalogue "Ethernet Network Solutions for the Industry B1/48"



Han® PushPull, type acc. to IEC/PAS 61 076-3-117 variant 14  
Housing bulkhead mounting for device integration and RJ45 jacks

**Features**

- HARTING PushPull technology
- Compact design
- High packing density
- Device integration via RJ45 PCB connectors

**Technical characteristics**

|                      |  |
|----------------------|--|
| Locking              | PushPull technology acc. to IEC/PAS 61 076-3-117 |
| Degree of protection | IP 65 / IP 67                                    |
| Mating face          | RJ45 acc. to IEC 60 603-7                        |
| Termination type     | Female with solder termination                   |
| Mating cycles        | min. 750   |
| Temperature range    | -40 °C ... +70 °C                                |
| Housing material     | Zinc die-cast, nickel plated                     |

| Identification | Part No. | Drawing | Dimensions in mm |
|----------------|----------|---------|------------------|
|----------------|----------|---------|------------------|

**Components device side**

Housing bulkhead mounting metal

09 35 002 0301

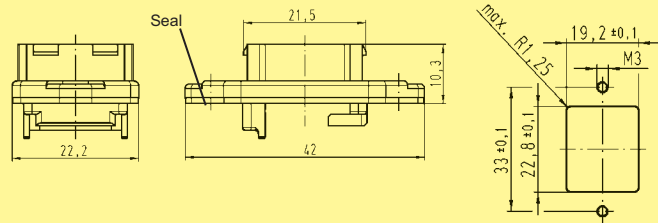

Dust protection cover IP 20 rubber (NBR)

09 35 002 5401

RJ45 female Solder variant, 90° angled

09 35 002 2101

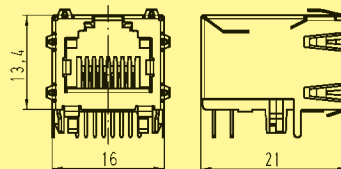

Solder variant, 180° straight

09 35 002 2102

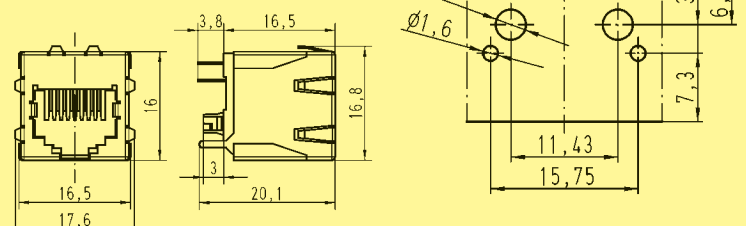





Han® PushPull, type acc. to IEC/PAS 61 076-3-117 variant 14  
RJ45 panel feed through

PushPull

**Features**

- HARTING PushPull technology
- Compact design
- High packing density
- Device integration via RJ45 PCB connectors

**Technical characteristics**

|                      |  |
|----------------------|--|
| Locking              | PushPull technology acc. to IEC/PAS 61 076-3-117 |
| Degree of protection | IP 65 / IP 67                                    |
| Mating face          | RJ45 acc. to IEC 60 603-7                        |
| Termination type     | Female with solder termination                   |
| Mating cycles        | min. 750   |
| Temperature range    | -40 °C ... +70 °C                                |
| Housing material     | Zinc die-cast, nickel plated                     |

Identification

Part No.

Drawing

Dimensions in mm

**Han® PushPull RJ45**

Panel feed through including housing and printed board with 2 x RJ45 jack horizontally mounted

09 35 221 0311

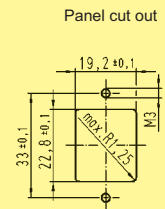
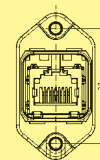
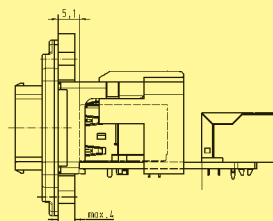

Panel feed through including housing and printed board with RJ45 jack and SEK board

09 35 222 0311

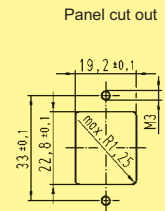
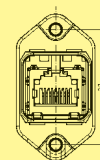
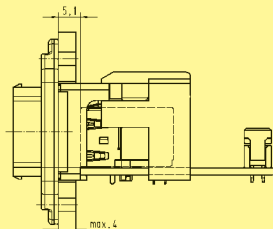

Panel feed through including housing and printed board with RJ45 jack and RJ45 jack vertically mounted in the IP20 range

09 35 223 0311

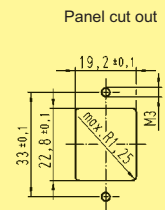
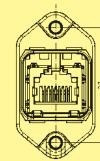
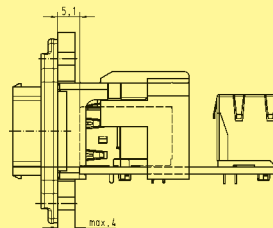

Identification

Part No.

Drawing

Dimensions in mm

Panel feed through including housing and printed board with RJ45 jack and 47° jack vertically mounted in the IP20 range

09 35 224 0311

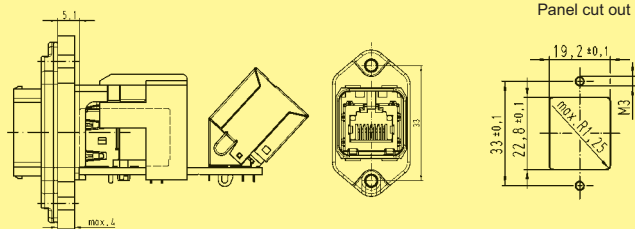

Panel feed through including housing and printed board with RJ45 jack and solder termination in the IP20 range

09 35 226 0311

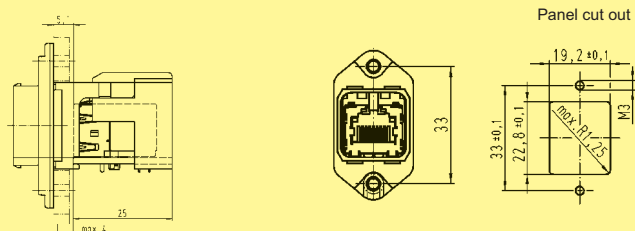

Recommendation for female insert and assembly manual on request.

PushPull



Han® PushPull, type acc. to IEC/PAS 61 076-3-117 variant 14 RJ45 connector

PushPull

Features

- HARTING PushPull technology
- Compact design
- High packing density
- Field-assembly connector with IDC contacts (Cat. 5 versions) or piercing contacts (Cat. 6 versions)

Technical characteristics

|                                      |   |
|--------------------------------------|---|
| Locking                              | PushPull technology acc. to IEC/PAS 61 076-3-117      |
| Degree of protection                 | IP 65 / IP 67   |
| Mating face                          | RJ45 acc. to IEC 60 603-7                             |
| Termination cross section for Cat. 5 | AWG 24/7 – 22/7 (stranded)<br>AWG 23/1 – 22/1 (solid) |
| for Cat. 6                           | AWG 24/7 – 27/7 (stranded)                            |
| Mating cycles                        | min. 750  |
| Temperature range                    | -40 °C ... +70 °C                                     |
| Housing material                     | Zinc die-cast, nickel plated                          |
| Cable diameter                       | 5 – 9.5 mm  |

Identification

Part No.

Drawing

Dimensions in mm

Connector set, metal

incl. housing and male insert

Category 5, 4-poles  
HARTING RJ Industrial®  
4 – 11 mm clamp range  
PROFINET-Identification:  
PROFINET O-Plug RJ45



Category 6, 8-poles  
4 – 11 mm clamp range  
Wire manager, white

Wire manager, blue

09 35 221 0401

09 35 223 0401

09 35 224 0401

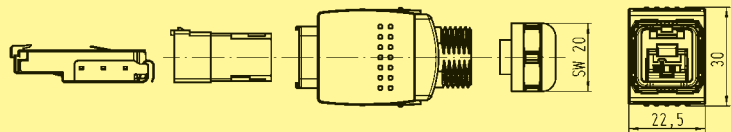

Tools

see page 01.08

Assembled system cables

see catalogue "Ethernet Network Solutions for the Industry B1/48"

Han® PushPull, type acc. to IEC/PAS 61 076-3-117 variant 14  
Accessories

| Identification | Part No. | Drawing | Dimensions in mm |
|----------------|----------|---------|------------------|
|----------------|----------|---------|------------------|

Han® PushPull  
dust protection cover  
for device side

09 35 002 5401



Han® PushPull  
dust protection cover  
for cable side

09 35 002 5412



Han® PushPull  
protection cover IP 65  
for cable side

09 35 002 5411





Han® PushPull, type acc. to IEC/PAS 61 076-3-117 variant 14  
Housing bulkhead mounting for device integration  
Optical connector based on SCRJ

PushPull

**Features**

- HARTING PushPull technology
- Compact design
- High packing density
- Device integration via transceiver
- Han® PushPull SCRJ for POF is according the requirements of AIDA (German Domestic Automobile Manufacturers)

**Technical characteristics**

|                            |  |
|----------------------------|--|
| Locking                    | PushPull technology acc. to IEC/PAS 61 076-3-117   |
| Degree of protection       | IP 65 / IP 67  |
| Mating face                | SCRJ acc. to IEC 50 377-3-6  |
| Fiber Typen                | POF <sup>1)</sup> 1 mm<br>HCS <sup>2)</sup> 200 µm / 230 µm<br>MM 62,5 µm / 125 µm<br>MM 50 µm / 125 µm<br>SM 10 µm / 125 µm |
| Mating cycles              | min. 750   |
| Temperature range          | -40 °C ... +70 °C  |
| Housing material           | Plastic, black   |
| Flammability acc. to UL 94 | V 0  |

| Identification | Part No. | Drawing | Dimensions in mm |
|----------------|----------|---------|------------------|
|----------------|----------|---------|------------------|

**Components device side**

Housing bulkhead mounting  
Optical transceiver  
not included

plastic

09 35 002 0323

Dust protection cover IP 20  
rubber (NBR)

09 35 002 5401

Reference for transceiver  
as well as mounting instruction  
on request

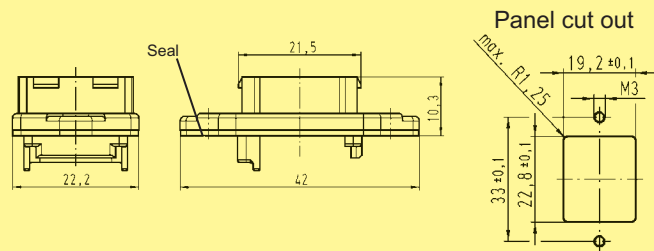

1) POF = Polymer-Optical Fibre  
2) HCS® = Hard Clad Silica (registered trademark of SpecTran Corporation)



Han® PushPull, type acc. to IEC/PAS 61 076-3-117 variant 14  
RJ45 panel feed through  
for optical connector based on SCRJ

**Features**

- HARTING PushPull technology
- Compact design
- High packing density
- Han® PushPull SCRJ for POF is according the requirements of AIDA (German Domestic Automobile Manufacturers)

**Technical characteristics**

|                            |  |
|----------------------------|--|
| Locking                    | PushPull technology acc. to IEC/PAS 61 076-3-117   |
| Degree of protection       | IP 65 / IP 67  |
| Mating face                | SCRJ acc. to IEC 50 377-3-6  |
| Fiber Typen                | POF <sup>1)</sup> 1 mm<br>HCS <sup>2)</sup> 200 µm / 230 µm<br>MM 62,5 µm / 125 µm<br>MM 50 µm / 125 µm<br>SM 10 µm / 125 µm |
| Mating cycles              | min. 750   |
| Temperature range          | -40 °C ... +70 °C  |
| Housing material           | Plastic, black   |
| Flammability acc. to UL 94 | V 0  |

**Identification**

**Part No.**

**Drawing**

**Dimensions in mm**

**Han® PushPull SCRJ**

Panel feed through

09 35 242 0333

SC contacts order separately

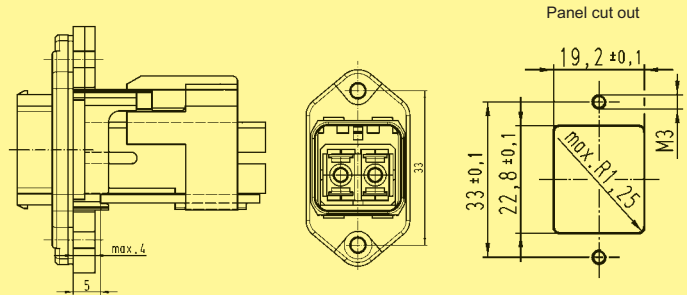

**Contacts**

|                      |                |
|----------------------|----------------|
| SC POF contact, 1 mm | 20 10 001 5217 |
| SC 125 GI contact    | 20 10 125 5211 |
| SC 230 HCS contact   | 20 10 230 5211 |



Han® PushPull, type acc. to IEC/PAS 61 076-3-117 variant 14  
SCRJ connector

PushPull

**Features**

- HARTING PushPull technology
- Compact design
- High packing density
- Han® PushPull SCRJ for POF is according the requirements of AIDA (German Domestic Automobile Manufacturers)

**Technical characteristics**

|                            |  |
|----------------------------|--|
| Locking                    | PushPull technology acc. to IEC/PAS 61 076-3-117   |
| Degree of protection       | IP 65 / IP 67  |
| Mating face                | SCRJ acc. to IEC 50 377-3-6  |
| Fiber Typen                | POF <sup>1)</sup> 1 mm<br>HCS <sup>2)</sup> 200 µm / 230 µm<br>MM 62,5 µm / 125 µm<br>MM 50 µm / 125 µm<br>SM 10 µm / 125 µm |
| Mating cycles              | min. 750   |
| Temperature range          | -40 °C ... +70 °C  |
| Housing material           | Plastic, black   |
| Flammability acc. to UL 94 | V 0  |

| Identification | Part No. | Drawing | Dimensions in mm |
|----------------|----------|---------|------------------|
|----------------|----------|---------|------------------|

**Connector set, plastic**  
incl. housing and SCRJ insert

PROFINET-Identification:  
PROFINET O-Plug SCRJ

SC contacts order separately



09 35 241 0422

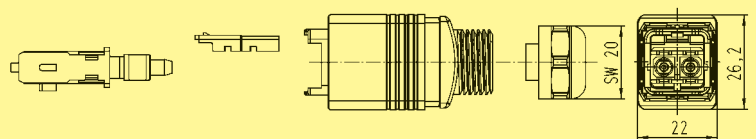

**Contacts**

|                      |                |
|----------------------|----------------|
| SC POF contact, 1 mm | 20 10 001 5217 |
| SC 125 GI contact    | 20 10 125 5211 |
| SC 230 HCS contact   | 20 10 230 5211 |



Han® PushPull, type acc. to IEC/PAS 61 076-3-117 variant 14  
Housing bulkhead mounting for device integration  
Optical connector based on SCRJ

**Features**

- HARTING PushPull technology
- Compact design
- High packing density
- Device integration via transceiver
- Han® PushPull SCRJ for POF is according the requirements of AIDA (German Domestic Automobile Manufacturers)

**Technical characteristics**

|                      |  |
|----------------------|--|
| Locking              | PushPull technology acc. to IEC/PAS 61 076-3-117   |
| Degree of protection | IP 65 / IP 67  |
| Mating face          | SCRJ acc. to IEC 50 377-3-6  |
| Fiber Typen          | POF <sup>1)</sup> 1 mm<br>HCS <sup>2)</sup> 200 µm / 230 µm<br>MM 62,5 µm / 125 µm<br>MM 50 µm / 125 µm<br>SM 10 µm / 125 µm |
| Mating cycles        | min. 750   |
| Temperature range    | -40 °C ... +70 °C  |
| Housing material     | Zinc die-cast, nickel plated   |

| Identification | Part No. | Drawing | Dimensions in mm |
|----------------|----------|---------|------------------|
|----------------|----------|---------|------------------|

**Components device side**

Housing bulkhead mounting  
Optical transceiver not included

metal

09 35 002 0303

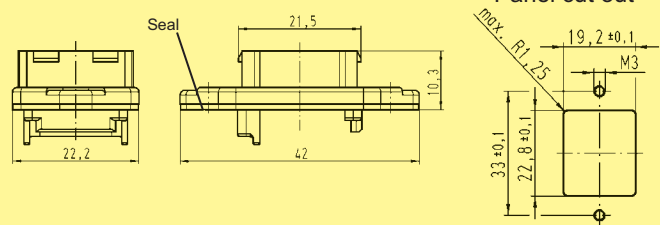

Dust protection cover IP 20  
rubber (NBR)

09 35 002 5401

Reference for transceiver  
as well as mounting instruction  
on request

1) POF = Polymer-Optical Fibre  
2) HCS® = Hard Clad Silica (registered trademark of SpecTran Corporation)





Han® PushPull, type acc. to IEC/PAS 61 076-3-117 variant 14  
 RJ45 panel feed through  
 for optical connector based on SCRJ

PushPull

## Features

- HARTING PushPull technology
- Compact design
- High packing density
- Han® PushPull SCRJ for POF is according the requirements of AIDA (German Domestic Automobile Manufacturers)

## Technical characteristics

|                      |  |
|----------------------|--|
| Locking              | PushPull technology acc. to IEC/PAS 61 076-3-117   |
| Degree of protection | IP 65 / IP 67  |
| Mating face          | SCRJ acc. to IEC 50 377-3-6  |
| Fiber Typen          | POF <sup>1)</sup> 1 mm<br>HCS <sup>2)</sup> 200 µm / 230 µm<br>MM 62,5 µm / 125 µm<br>MM 50 µm / 125 µm<br>SM 10 µm / 125 µm |
| Mating cycles        | min. 750   |
| Temperature range    | -40 °C ... +70 °C  |
| Housing material     | Zinc die-cast, nickel plated   |

### Identification

### Part No.

### Drawing

### Dimensions in mm

## Han® PushPull SCRJ

Panel feed through

09 35 242 0313

SC contacts order separately

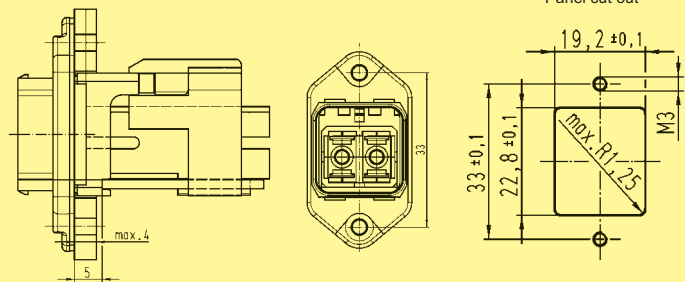

## Contacts

|                      |                |
|----------------------|----------------|
| SC POF contact, 1 mm | 20 10 001 5217 |
| SC 125 GI contact    | 20 10 125 5211 |
| SC 230 HCS contact   | 20 10 230 5211 |



Han® PushPull, type acc. to IEC/PAS 61 076-3-117 variant 14 SCRJ connector

**Features**

- HARTING PushPull technology
- Compact design
- High packing density
- Han® PushPull SCRJ for POF is according the requirements of AIDA (German Domestic Automobile Manufacturers)

**Technical characteristics**

|                            |  |
|----------------------------|--|
| Locking                    | PushPull technology acc. to IEC/PAS 61 076-3-117   |
| Degree of protection       | IP 65 / IP 67  |
| Mating face                | SCRJ acc. to IEC 50 377-3-6  |
| Fiber Typen                | POF <sup>1)</sup> 1 mm<br>HCS <sup>2)</sup> 200 µm / 230 µm<br>MM 62,5 µm / 125 µm<br>MM 50 µm / 125 µm<br>SM 10 µm / 125 µm |
| Mating cycles              | min. 750   |
| Temperature range          | -40 °C ... +70 °C  |
| Housing material           | Zinc die-cast, nickel plated   |
| Flammability acc. to UL 94 | V 0  |

Identification

Part No.

Drawing

Dimensions in mm

**Connector set, metal**  
incl. housing and SCRJ insert

PROFINET-Identification:  
PROFINET O-Plug SCRJ

SC contacts order separately

09 35 241 0402

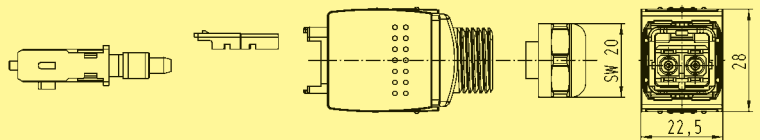

**Contacts**

SC POF contact, 1 mm  
SC 125 GI contact  
SC 230 HCS contact

20 10 001 5217  
20 10 125 5211  
20 10 230 5211



Han® PushPull, type acc. to IEC/PAS 61 076-3-117 variant 14  
Housing bulkhead mounting and power females for device integration

PushPull

Features

- HARTING PushPull technology
- Compact, space-saving design
- Touch-proof
- Device side: male
  - Solder variant, angled

Technical characteristics

|                                       |  |
|---------------------------------------|--|
| Locking                               | PushPull technology acc. to IEC/PAS 61 076-3-117 |
| Degree of protection                  | IP 65 / IP 67                                    |
| Number of contacts                    | 4 + PE   |
| Electrical data acc. to DIN EN 61 984 | 16 A 230/400 V 4 kV 3                            |
| Termination                           | Male insert with solder termination              |
| Mating cycles                         | min. 500   |
| Temperature range                     | -40 °C ... +85 °C                                |
| Housing material                      | Plastic, black                                   |
| Flammability acc. to UL 94            | V 0  |

| Identification | Part No. | Drawing | Dimensions in mm |
|----------------|----------|---------|------------------|
|----------------|----------|---------|------------------|

Components device side

|  |                |  |
|--|----------------|--|
| Housing bulkhead mounting plastic            | 09 35 002 0323 |  |
| Dust protection cover IP 20, rubber (NBR)    | 09 35 002 5401 |  |
| Male insert with solder termination angled   | 09 35 002 3003 |  |
| Male insert with solder termination straight | 09 35 002 3004 |  |

Panel cut out

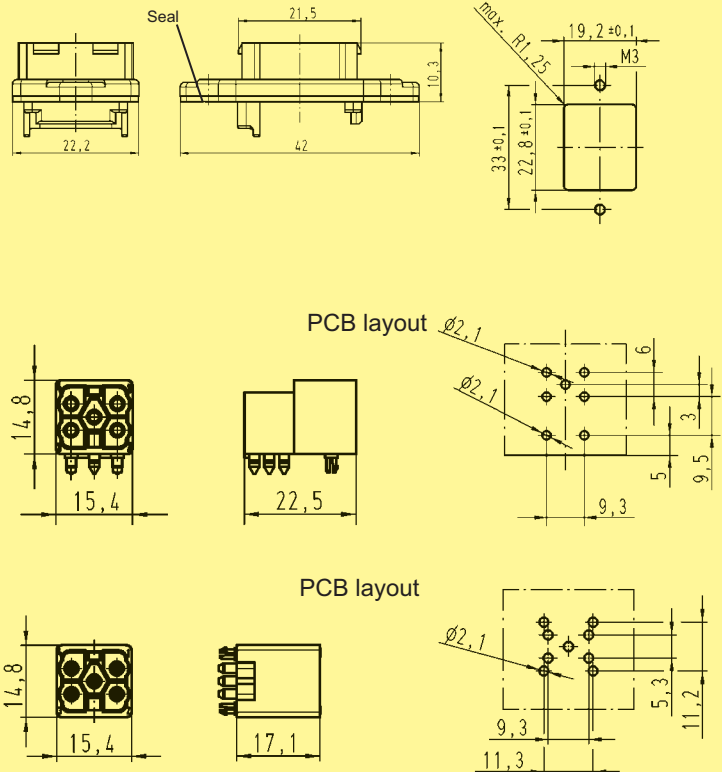



Han® PushPull, type acc. to IEC/PAS 61 076-3-117 variant 14  
 Panel feed-through, 5-poles, 230/400 V, 16 A

**Features**

- HARTING PushPull technology
- Compact, space-saving design
- Touch-proof
- Panel feed-through
  - crimp termination
  - Han-Quick Lock® termination
  - solder termination

**Technical characteristics**

|                                       |  |
|---------------------------------------|--|
| Locking                               | PushPull technology acc. to IEC/PAS 61 076-3-117 |
| Degree of protection                  | IP 65 / IP 67                                    |
| Number of contacts                    | 4 + PE   |
| Electrical data acc. to DIN EN 61 984 | 16 A 690 V 4 kV 3                                |
| • with solder termination             | 16 A 230/400 V 4 kV 3                            |
| Termination cross section             | 0,5 – 2,5 mm <sup>2</sup>                        |
| Mating cycles                         | min. 500   |
| Temperature range                     | -40 °C ... +85 °C                                |
| Housing material                      | Plastic, black                                   |
| Flammability acc. to UL 94            | V 0  |

| Identification   | Part No.       | Drawing | Dimensions in mm   |
|--|----------------|---------|--|
| Panel feed through including housing and male insert<br>16 A 690 V<br>with crimp termination<br>please order crimp contacts separately | 09 35 231 0333 |         | Panel cut out<br>19,2 ± 0,1<br>33 ± 0,1<br>72,8 ± 0,1<br>M3<br>R1,25 |
| Panel feed through including housing and male insert<br>16 A 690 V<br>with Han-Quick Lock® termination                                 | 09 35 232 0333 |         | Panel cut out<br>19,2 ± 0,1<br>33 ± 0,1<br>72,8 ± 0,1<br>M3<br>R1,25 |
| Panel feed through including housing and male insert<br>16 A, 230/400 V<br>on PCB<br>with solder termination                           | 09 35 233 0333 |         | Panel cut out<br>19,2 ± 0,1<br>33 ± 0,1<br>72,8 ± 0,1<br>M3<br>R1,25 |

PushPull



Han® PushPull, type acc. to IEC/PAS 61 076-3-117 variant 14  
 Connector, 5-poles, 230/400 V, 16 A

PushPull

Features

- HARTING PushPull technology
- Compact, space-saving design
- Touch-proof
- Cable side: female
  - crimp termination
  - Han-Quick Lock® termination technology
 Field-assembly without special tools

Technical characteristics

|                                       |  |
|---------------------------------------|--|
| Locking                               | PushPull technology acc. to IEC/PAS 61 076-3-117 |
| Degree of protection                  | IP 65 / IP 67                                    |
| Number of contacts                    | 4 + PE   |
| Electrical data acc. to DIN EN 61 984 | 16 A 690 V 4 kV 3                                |
| • with solder termination             | 16 A 230/400 V 4 kV 3                            |
| Termination cross section             | 0,5 – 2,5 mm <sup>2</sup>                        |
| Mating cycles                         | min. 500   |
| Temperature range                     | -40 °C ... +85 °C                                |
| Cable diameter                        | 6.5 – 13 mm                                      |
| Housing material                      | Plastic, black                                   |
| Flammability acc. to UL 94            | V 0  |

| Identification | Part No. | Drawing | Dimensions in mm |
|----------------|----------|---------|------------------|
|----------------|----------|---------|------------------|

Connector set, plastic

incl. housing and female insert

with crimp termination  
 9 – 13 mm clamp range  
 Han® P crimp contacts  
 order separately

09 35 231 0423

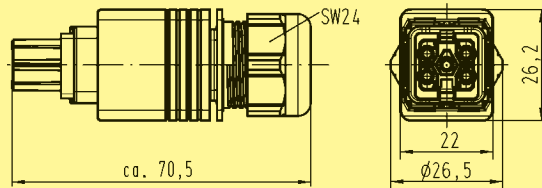

with Han-Quick Lock® termination  
 9 – 13 mm clamp range

09 35 232 0423



Han-Quick Lock®

with Han-Quick Lock® termination  
 6.5 – 9.5 mm clamp range

09 35 232 0421



Han-Quick Lock®

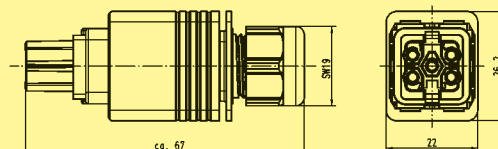





Han® PushPull, type acc. to IEC/PAS 61 076-3-117 variant 14  
 Panel feed-through, 5-poles, 16 A

PushPull

Features

- HARTING PushPull technology
- Compact, space-saving design
- Touch-proof
- Panel feed-through
  - crimp termination
  - Han-Quick Lock® termination
  - solder termination

Technical characteristics

|                                       |  |
|---------------------------------------|--|
| Locking                               | PushPull technology acc. to IEC/PAS 61 076-3-117 |
| Degree of protection                  | IP 65 / IP 67                                    |
| Number of contacts                    | 4 + PE   |
| Electrical data acc. to DIN EN 61 984 | 16 A 690 V 4 kV 3                                |
| • with solder termination             | 16 A 230/400 V 4 kV 3                            |
| Termination cross section             | 0,5 – 2,5 mm <sup>2</sup>                        |
| Mating cycles                         | min. 500   |
| Temperature range                     | -40 °C ... +85 °C                                |
| Housing material                      | Zinc die-cast, nickel plated                     |

| Identification | Part No. | Drawing | Dimensions in mm |
|----------------|----------|---------|------------------|
|----------------|----------|---------|------------------|

Panel feed through including housing and male insert  
 16 A, 690 V  
 with crimp termination  
 please order crimp contacts separately

09 35 231 0313

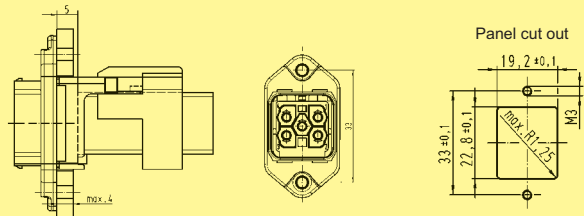

Panel feed through including hood and male insert  
 16 A, 690 V  
 with Han-Quick Lock® termination

09 35 232 0313

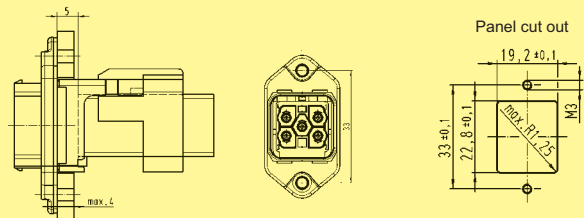

Panel feed through including hood and male insert  
 16 A, 230/400 V  
 on PCB with solder termination

09 35 233 0313

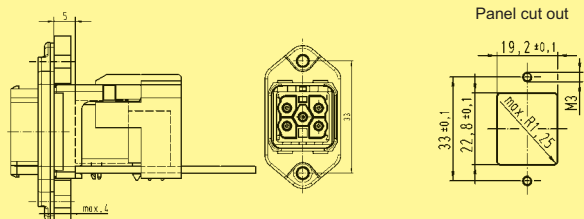







Han® PushPull, type acc. to IEC/PAS 61 076-3-117 variant 14  
Accessories

PushPull

| Identification                                     | Part No.       | Drawing  | Dimensions in mm |
|--|----------------|--|------------------|
| BUCHANAN-crimping tool                             | 09 99 000 0001 |    |                  |
| Locator Han P®<br>for crimping tool 09 99 000 0001 | 09 99 000 0329 |  |                  |
| Multiple crimping tool depth<br>adjustment gauge   | 09 99 000 0379 | Wire gauge<br>0.5 - 1 mm <sup>2</sup> ø 1.55<br>1.5 - 2.5 mm <sup>2</sup> ø 1.80     |                  |
| Removal tool Han P®                                | 09 99 000 0319 |  |                  |

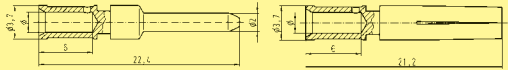
| Identification                         | Part number              |                | Drawing        | Dimensions in mm  |                  |  |   |                  |                         |        |         |      |                          |        |         |      |                         |        |         |      |                         |        |         |      |                         |        |         |      |
|--|--------------------------|----------------|----------------|---|------------------|--|---|------------------|-------------------------|--------|---------|------|--------------------------|--------|---------|------|-------------------------|--------|---------|------|-------------------------|--------|---------|------|-------------------------|--------|---------|------|
|  | Male contact             | Female contact |                |   |                  |  |   |                  |                         |        |         |      |                          |        |         |      |                         |        |         |      |                         |        |         |      |                         |        |         |      |
| Crimp contacts Han® P<br>silver plated | for 0.5 mm <sup>2</sup>  | 09 35 000 6103 | 09 35 000 6203 |  <table border="1"> <thead> <tr> <th colspan="2">Wire gauge</th> <th>Ø</th> <th>Stripping length</th> </tr> </thead> <tbody> <tr> <td>for 0.5 mm<sup>2</sup></td> <td>AWG 20</td> <td>1.15 mm</td> <td>6 mm</td> </tr> <tr> <td>for 0.75 mm<sup>2</sup></td> <td>AWG 18</td> <td>1.30 mm</td> <td>6 mm</td> </tr> <tr> <td>for 1.0 mm<sup>2</sup></td> <td>AWG 18</td> <td>1.45 mm</td> <td>6 mm</td> </tr> <tr> <td>for 1.5 mm<sup>2</sup></td> <td>AWG 16</td> <td>1.75 mm</td> <td>6 mm</td> </tr> <tr> <td>for 2.5 mm<sup>2</sup></td> <td>AWG 14</td> <td>2.25 mm</td> <td>6 mm</td> </tr> </tbody> </table> | Wire gauge       |  | Ø | Stripping length | for 0.5 mm <sup>2</sup> | AWG 20 | 1.15 mm | 6 mm | for 0.75 mm <sup>2</sup> | AWG 18 | 1.30 mm | 6 mm | for 1.0 mm <sup>2</sup> | AWG 18 | 1.45 mm | 6 mm | for 1.5 mm <sup>2</sup> | AWG 16 | 1.75 mm | 6 mm | for 2.5 mm <sup>2</sup> | AWG 14 | 2.25 mm | 6 mm |
|  | Wire gauge               |                | Ø              |   | Stripping length |  |   |                  |                         |        |         |      |                          |        |         |      |                         |        |         |      |                         |        |         |      |                         |        |         |      |
|  | for 0.5 mm <sup>2</sup>  | AWG 20         | 1.15 mm        |   | 6 mm             |  |   |                  |                         |        |         |      |                          |        |         |      |                         |        |         |      |                         |        |         |      |                         |        |         |      |
|  | for 0.75 mm <sup>2</sup> | AWG 18         | 1.30 mm        |   | 6 mm             |  |   |                  |                         |        |         |      |                          |        |         |      |                         |        |         |      |                         |        |         |      |                         |        |         |      |
|  | for 1.0 mm <sup>2</sup>  | AWG 18         | 1.45 mm        |   | 6 mm             |  |   |                  |                         |        |         |      |                          |        |         |      |                         |        |         |      |                         |        |         |      |                         |        |         |      |
| for 1.5 mm <sup>2</sup>                | AWG 16                   | 1.75 mm        | 6 mm           |   |                  |  |   |                  |                         |        |         |      |                          |        |         |      |                         |        |         |      |                         |        |         |      |                         |        |         |      |
| for 2.5 mm <sup>2</sup>                | AWG 14                   | 2.25 mm        | 6 mm           |   |                  |  |   |                  |                         |        |         |      |                          |        |         |      |                         |        |         |      |                         |        |         |      |                         |        |         |      |
| for 0.75 mm <sup>2</sup>               | 09 35 000 6104           | 09 35 000 6204 |                |   |                  |  |   |                  |                         |        |         |      |                          |        |         |      |                         |        |         |      |                         |        |         |      |                         |        |         |      |
| for 1.0 mm <sup>2</sup>                | 09 35 000 6105           | 09 35 000 6205 |                |   |                  |  |   |                  |                         |        |         |      |                          |        |         |      |                         |        |         |      |                         |        |         |      |                         |        |         |      |
| for 1.5 mm <sup>2</sup>                | 09 35 000 6106           | 09 35 000 6206 |                |   |                  |  |   |                  |                         |        |         |      |                          |        |         |      |                         |        |         |      |                         |        |         |      |                         |        |         |      |
| for 2.5 mm <sup>2</sup>                | 09 35 000 6107           | 09 35 000 6207 |                |   |                  |  |   |                  |                         |        |         |      |                          |        |         |      |                         |        |         |      |                         |        |         |      |                         |        |         |      |



Housing bulkhead mounting and power females for device integration

**Features**

- HARTING PushPull technology
- Touch-proof
- Device side: male
  - Solder variant, angled and straight
- AIDA-conform  
(German Domestic Automobile Manufactures)

**Technical characteristics**

|                                       |  |
|---------------------------------------|--|
| Locking                               | PushPull technology acc. to IEC/PAS 61 076-3-117 |
| Degree of protection                  | IP 65 / IP 67                                    |
| Number of contacts                    | 4 + PE   |
| Electrical data acc. to DIN EN 61 984 | 16 A 24 V 4 kV 3                                 |
| Termination                           | Male insert with solder termination              |
| Mating cycles                         | min. 500   |
| Temperature range                     | -40 °C ... +70 °C                                |
| Housing material                      | Plastic, black                                   |
| Flammability acc. to UL 94            | V 0  |

| Identification | Part No. | Drawing | Dimensions in mm |
|----------------|----------|---------|------------------|
|----------------|----------|---------|------------------|

**Components device side**

Housing bulkhead mounting plastic

09 35 004 0321

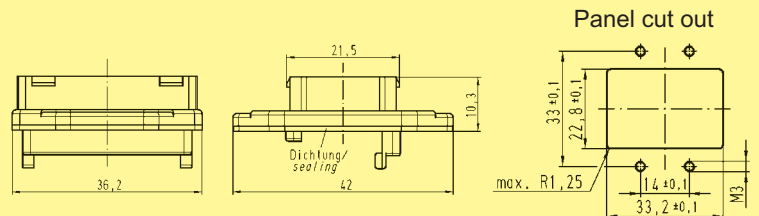

Male insert with solder termination angled

09 35 004 3003

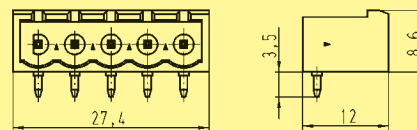

Male insert with solder termination straight

09 35 004 3004

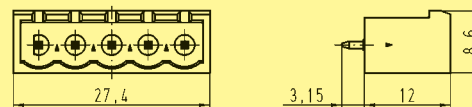

**Set components device side, plastic**

incl. housing and male insert with solder termination angled

09 35 431 0321

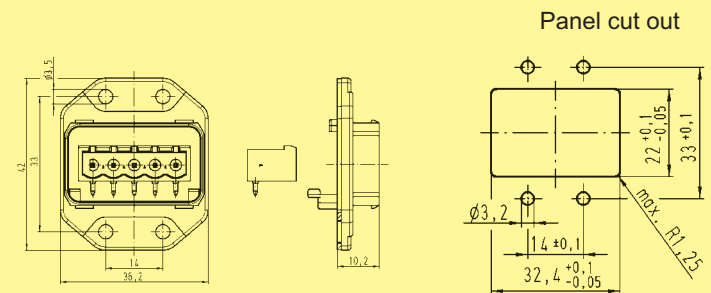

PushPull



Connector, 5-poles, 24 V, 16 A

PushPull

## Features

- HARTING PushPull technology
- Touch-proof
- Cable side: female  
- spring force connection
- AIDA-conform  
(German Domestic Automobile  
Manufactures)

## Technical characteristics

|                                       |  |
|---------------------------------------|--|
| Locking                               | PushPull technology acc. to IEC/PAS 61 076-3-117 |
| Degree of protection                  | IP 65 / IP 67                                    |
| Number of contacts                    | 4 + PE   |
| Electrical data acc. to DIN EN 61 984 | 16 A 24 V 4 kV 3                                 |
| Termination                           | Spring force connection                          |
| Termination cross section             | 0.75 ... 2.5 mm <sup>2</sup>                     |
| Mating cycles                         | min. 500   |
| Temperature range                     | -40 °C ... +70 °C                                |
| Cable diameter                        | 9 – 13 mm  |
| Housing material                      | Plastic, black                                   |
| Flammability acc. to UL 94            | V 0  |

Identification

Part No.

Drawing

Dimensions in mm

### Connector set, plastic

incl. housing  
and female insert  
with spring force connection



09 35 431 0421

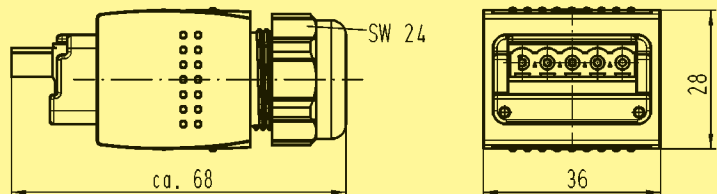



Housing bulkhead mounting and power females for device integration

**Features**

- HARTING PushPull technology
- Touch-proof
- Device side: male
  - Solder variant, angled and straight
- AIDA-conform  
(German Domestic Automobile Manufactures)

**Technical characteristics**

|                                       |   |
|---------------------------------------|---|
| Locking                               | PushPull technology acc. to IEC/PAS 61 076-3-117        |
| Degree of protection                  | IP 65 / IP 67   |
| Number of contacts                    | 4 + PE  |
| Electrical data acc. to DIN EN 61 984 | 16 A 24 V 4 kV  |
| Termination                           | Male insert with solder termination                     |
| Mating cycles                         | min. 500  |
| Temperature range                     | -40 °C ... +70 °C                                       |
| Housing material                      | Zinc die-cast, nickel plated<br>Plastic, black (female) |

| Identification | Part No. | Drawing | Dimensions in mm |
|----------------|----------|---------|------------------|
|----------------|----------|---------|------------------|

**Components device side**

Housing bulkhead mounting metal

09 35 004 0301

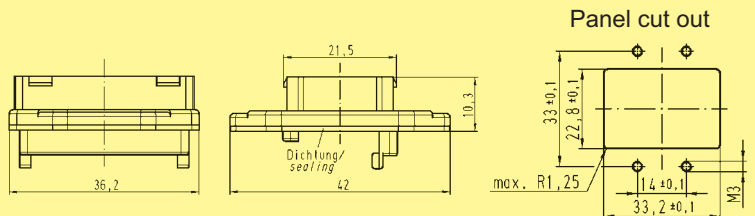

Male insert with solder termination angled

09 35 004 3003

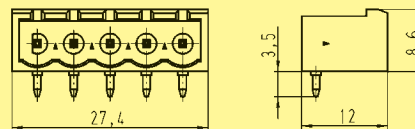

Male insert with solder termination straight

09 35 004 3004

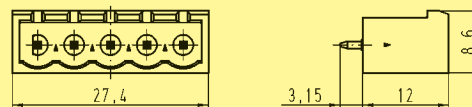

**Set components device side, metal**

incl. housing and male insert with solder termination angled

09 35 431 0301

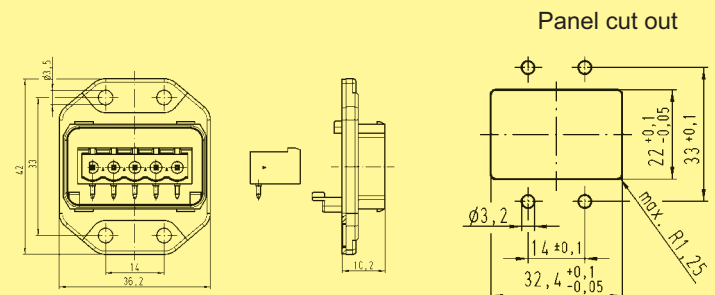

PushPull



Connector, 5-poles, 24 V, 16 A

PushPull

### Features

- HARTING PushPull technology
- Touch-proof
- Cable side: female  
- spring force connection
- AIDA-conform  
(German Domestic Automobile Manufactures)

### Technical characteristics

|                                       |  |
|---------------------------------------|--|
| Locking                               | PushPull technology acc. to IEC/PAS 61 076-3-117 |
| Degree of protection                  | IP 65 / IP 67                                    |
| Number of contacts                    | 4 + PE   |
| Electrical data acc. to DIN EN 61 984 | 16 A 24 V 4 kV 3                                 |
| Termination                           | Spring force connection                          |
| Termination cross section             | 0.75 ... 2.5 mm <sup>2</sup>                     |
| Mating cycles                         | min. 500   |
| Temperature range                     | -40 °C ... +70 °C                                |
| Cable diameter                        | 9 – 13 mm  |
| Housing material                      | Zinc die-cast, nickel plated                     |

Identification

Part No.

Drawing

Dimensions in mm

#### Connector set, metal

incl. housing and female insert with spring force connection



09 35 431 0401

